



## EVALUATION GUIDANCE OF LIQUID WASTE PROCESSING SYSTEM IN ELECTROPLATING UMKM CV. XYZ

G. Awaludin Sobarsah<sup>1\*</sup>, Lintang Rizkyta Ananda<sup>2</sup>, Alissya Rafiani<sup>3</sup>,  
Mohammad Ghinnastiar Ulsak<sup>4</sup>, Rendi Mukti<sup>5</sup>

<sup>1,2,3,4,5</sup>Setia Budhi University, Rangkasbitung, Indonesia

Email: [gawaludi1308@gmail.com](mailto:gawaludi1308@gmail.com)<sup>1</sup>; [lintangrizkyta@gmail.com](mailto:lintangrizkyta@gmail.com)<sup>2</sup>; [alisyarafiani@gmail.com](mailto:alisyarafiani@gmail.com)<sup>3</sup>; [mgulsak@gmail.com](mailto:mgulsak@gmail.com)<sup>4</sup>; [rendy01.mukti@gmail.com](mailto:rendy01.mukti@gmail.com)<sup>5</sup>

### Abstract

Development in the industrial sector on the one hand will produce goods and services that are beneficial for the welfare of the people, and on the other hand, industrial activities will produce waste. The problem of industrial waste is increasingly worrying, especially the waste produced generally contains toxic and hazardous chemicals. One of them is waste containing heavy metals. This community research aims to assist in the evaluation of the electroplating liquid waste processing process at UMKM CV. XYZ with parameters of Cr, Zn, Cd, CN-, total suspended solids (TSS) and acidity values (pH). The method used is to apply SK. MENLH. No. KEP-51 / MENLH / 10/1995, if the waste is directly disposed of into the environment it will cause pollution to other living things. Therefore, the process of reducing the concentration of metals is carried out by neutralization and coagulation, so that the metals that are discharged are in accordance with the quality standard. The results of the application concluded that the inlet concentration of chromium metal was 0.48 µg/L, zinc 1.83 mg/L, cyanide compound 0.02 mg/L, total suspended solids (TSS) 195.3 and the degree of acidity (pH) 10.6 and decreased to chromium metal 0.19 µg/L, zinc 1.48 mg/L, cyanide compound 0.0043 mg/L, total suspended solids (TSS) 52.6 and the degree of acidity (pH) 9 at the outlet that is discharged into the environment. So that the efficiency level of each parameter is obtained: TSS 73.11%, pH 12.36%, chromium metal 43.75%, zinc 19.13% and cyanide compound 78.5%.

**Keywords:** Liquid Waste Treatment, Electroplating UMKM, PKM Setia Budhi University

### INTRODUCTION

The management of liquid waste generated from the electroplating process in small and medium industries (SMEs) is still a serious problem, especially in technical and environmental aspects. SMEs such as CV. XYZ which is engaged in metal plating often do not have a liquid waste processing system that meets standards, both in terms of design and operational efficiency. The waste produced generally contains heavy metals such as chromium, nickel, and zinc which if disposed of without treatment can pollute water bodies and endanger public health. Based on the findings of Setyaningsih and Prabowo (2018), many small industries do not yet understand the importance of designing a proper liquid waste processing system and do not yet have the technical ability to operate waste treatment installations optimally.

Through the evaluation assistance activities of the liquid waste processing system at CV. XYZ, it is hoped that there will be an increase in awareness and technical ability of SME actors in managing industrial waste sustainably. This evaluation includes identifying critical points in the existing system, improving the process, and technical training related to the operation and maintenance of waste processing units. In line with the opinion of Setyaningsih and Prabowo (2018), the success of the waste processing system in MSMEs is not only determined by the availability of technology, but also by the active involvement of industry players and ongoing assistance from external parties such as

academics or the government. Therefore, this activity is important to ensure that liquid waste management not only meets regulatory requirements, but also supports business sustainability.

The problem of industrial waste is increasingly worrying, especially the waste produced generally contains toxic and hazardous chemicals. One of them is waste containing heavy metals. Therefore, wastewater treatment is very important. To treat this wastewater, a wastewater treatment unit is needed, so that the wastewater that will be discharged into open waters can meet the established quality standards.

The technology for waste management has not been widely cared for and considered by the industry, in addition to the lack of knowledge about how to properly treat waste and the lack of awareness of the industry towards the surrounding environment. So, it is necessary to develop industrial waste treatment technology (Kurniawan, & Santosa, 2019).

The waste released from the metal plating industry and other metal industries is a serious problem, because the metal is very toxic and can cause other effects on water. The metals in question are heavy metals including nickel, chromium, zinc, cadmium and copper. Therefore, wastewater from the electroplating process at UMKM CV. XYZ also undergoes treatment with neutralization and coagulation before being discharged into open waters according to the quality standards set by the government, namely SK. Minister of State for the Environment No. KEP-51/MENLH/10/1995. To determine the process of wastewater discharged into the environment, research was conducted from the inlet and outlet with parameters of chromium, cadmium, zinc, TSS (Total Suspended Solid), Cyanide and pH metal concentrations.

The electroplating process is the coating of a metal with another metal by electrolysis. Electrolysis is the event of electrical conduction through an electrolyte solution accompanied by a reduction-oxidation reaction (Arifin, & Widodo, 2021); (Hidayat, & Lestari, 2020). The reduction reaction occurs at the cathode and the oxidation reaction occurs at the anode. The electroplating process aims to increase hardness and prevent corrosion or rust (Purba, 1998). According to Ghani (1996), the stages of the metal coating process that need to be considered are (1) The process of cleaning fat, (2) The process of cleaning rust (pickling), (3) The rinsing process, and (4) The coating process.

Therefore, it is necessary to provide assistance in evaluating the electroplating liquid waste processing process at UMKM CV. XYZ. PKM activities by Lecturers of the Chemical Engineering Study Program, FTP, Setia Budhi University Rangkasbitung in this case carry out Community Service (PKM) activities, one of which is the field of Appropriate Technology which is a special concern in the learning process at the KKM which is ongoing and is considered interesting to implement.



Figure 1. Photo of PKM Lecturers and Management of UMKM CV. XYZ

## METHOD OF IMPLEMENTATION

The PKM activities in the field of Appropriate Technology in the PKM Lecturer of the Chemical Engineering Study Program, FTP, Setia Budhi University Rangkasbitung were carried out with two activities, namely analysis and evaluation of the assistance of the electroplating liquid waste processing process at UMKM CV. XYZ. The stages of implementing PKM assistance for the evaluation of the electroplating liquid waste processing process at UMKM CV. XYZ, namely:

1. Determine the problem or area
2. Determine the goals and targets
3. Form a team
4. Provide training on the integrated electroplating waste processing system
5. Conduct measurements and analysis
6. Implement corrective actions
7. Check the results
8. Follow up or follow-up
9. Repeat the cycle



Figure 1. Electroplating Waste Reservoir for UMKM CV. XYZ

Preparation is done by surveying and analysing the mapping area of CV. XYZ MSMEs and discussing with the management regarding the problems of the electroplating waste processing system in their area. The electroplating process at CV. XYZ MSMEs can be explained as follows:

1. Washing process. This tub contains an alkali solution (SE 3000) with a concentration of 80-100 g/L and a temperature of 60-90°C. This solution functions to clean organic dirt such as oil, grease, fat and others on the surface of the object to be coated. This process lasts for 10 minutes.
2. Rinsing process. This process functions to clean the remains of the previous process that are still left on the surface of the object to be coated using filtered water. This process lasts about one minute.
3. Anodic cleaning process (electro cleaner). This tub contains an alkali solution (SE 3000) with a concentration of 65-85 g/L and a temperature of 60-90°C. This solution functions to clean organic dirt that is not perfect or cannot be cleaned by the washing process such as polishing residue. This process lasts for 3-5 minutes.
4. Rinsing process. The use of distilled water from the well as a rinse that functions to clean the remaining contents of the cleaning solution that are still slightly left behind.
5. Cleaning process with acid (Acid Pickling). This tub contains HCl solution with a concentration of 20-25%. This solution functions to clean inorganic dirt such as rust, oxides and others, and neutralize washing residue. This process lasts for 10 minutes.
6. Rinsing process. Using distilled water from the well as a rinse.
7. Neutralization process. This tank contains a solution of NaOH and organic additives (envirozin conditioner) with a concentration of 30%. This solution functions to neutralize the remains of the previous washing process. This process lasts for 1 minute.
8. Zinc coating process. This tank contains zinc metal (Zn) as an anode and forming a layer on the object to be coated, zinc oxide (ZnO), sodium hydroxide (NaOH), and organic additives as conditioners and brighteners. At this stage the temperature of the solution is 20-40°C.
9. Drag out process. This tank contains distilled water which functions to accommodate the remaining zinc coating solution.
10. Rinsing process. Using distilled water as a rinsing medium which functions to clean the remains of the previous process.
11. Activation process. This tank contains HNO<sub>3</sub> with a concentration of 0.25-0.5%. This solution functions to activate the surface of the object. This process lasts for 5-10 seconds.
12. Rinsing process. Using distilled water as a rinse that functions to clean the remains of the previous process.
13. Chrome plating process. Is a final coating process that functions to maintain the hardness level of the object. This process lasts for 33 seconds.

14. Rinsing process. Using distilled water as a medium that functions to clean the remains of the previous process.

The implementation of PKM activities by lecturers at UMKM CV. XYZ was carried out by making an evaluation of the waste processing flow scheme which can be seen in the image below.

Notes:

- A : Chrome Waste Cell
- B : Zinc Waste Cell
- C : Neutralization Tank
- D : Coagulation Tank
- E : NaOH/HNO<sub>3</sub>
- F : Polymer
- G : pH adjusting tank
- H : pH adjusting tank
- I : solid waste tank
- J : Effluent

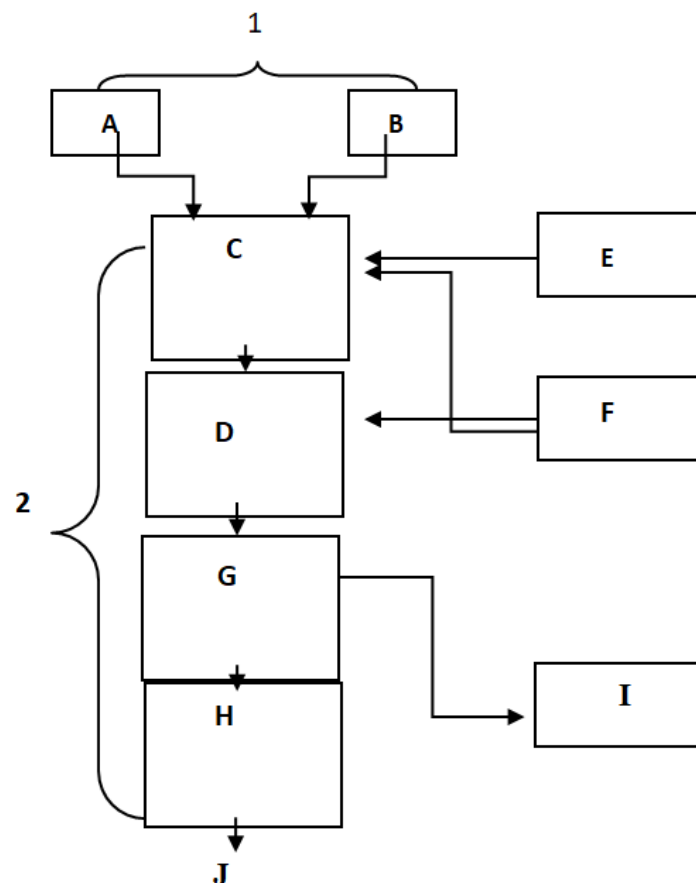

Figure 3. Waste Processing Flow Scheme at UMKM CV. XYZ

## ACTIVITY RESULTS AND DISCUSSION

The implementation of the concentration of metals in the electroplating wastewater treatment unit for each parameter is still below the standard quality standards and the processing efficiency in the electroplating wastewater treatment unit, zinc metal for each parameter is still below the standard quality standards. The PKM assistance evaluation suggests that the neutralization system needs to be carried out continuously by taking into account the waste discharge and the discharge of base and acid neutralizers. COD (Chemical Oxygen Demand) levels and permanganate numbers (organic substances) need to be determined to obtain representative test parameters even though they are not required in the standard quality.

## **CONCLUSION**

Based on the results of the Community Partnership Program (PKM) activities in the field of Appropriate Technology carried out at the electroplating wastewater treatment unit of CV. XYZ, it can be concluded that the existing wastewater treatment system demonstrates an initial performance that is relatively good. This is indicated by the concentration of heavy metals such as zinc and others in the treated wastewater, which remain below the threshold of environmental quality standards. However, although the metal concentrations meet safety limits, the processing efficiency for each metal parameter, particularly zinc, is still not optimal. This indicates that improvements in both technical and operational aspects of the treatment system are needed.

The evaluation and assistance provided through the PKM activities offered important recommendations, particularly regarding the need for a more sustainable neutralization system. Neutralization must be carried out continuously, taking into account the wastewater discharge and the accurate dosing of base and acid neutralizers to ensure a balanced and effective process. Additionally, even though parameters such as Chemical Oxygen Demand (COD) and permanganate index are not explicitly required in the environmental quality standards, their measurement is highly recommended. These parameters provide a more comprehensive picture of the organic content in the wastewater and the effectiveness of the treatment system.

Through this PKM activity, small-scale industry operators gained a deeper understanding of the importance of monitoring and improving wastewater treatment systems continuously. This contributes not only to environmental sustainability but also to the long-term viability of electroplating businesses such as CV. XYZ.

## **ACKNOWLEDGEMENTS**

We would like to express our gratitude to those who have supported the implementation of PKM in the field of Appropriate Technology to:

1. Management of UMKM CV. XYZ Electroplating
2. Fellow Lecturers of PKM Setia Budhi University Rangkasbitung

## REFERENCES

- Arifin, M. Z., & Widodo, T. (2021). "Strategi Pengelolaan Limbah Cair Industri Elektroplating pada UMKM Ramah Lingkungan." *Jurnal Teknologi Lingkungan*, 22(2), 135–144. <https://doi.org/10.29122/jtl.v22i2.4567>
- BAPEDAL. 1998. *Buku Panduan Teknologi Pengendalian Dampak Lingkungan Industri Tekstil*. Badan Pengendalian Dampak Lingkungan. Jakarta.
- Ghani, Abdul. 1996. *Pengolahan Limbah Industri Lapis Listrik*. Diklat Teknis Pengolahan Pencemaran Industri. Departemen Kesehatan. Jakarta.
- Hidayat, R., & Lestari, I. (2020). "Pendampingan Teknis dan Evaluasi Sistem IPAL pada UMKM: Studi Kasus Industri Logam di Jawa Barat." *Jurnal Pengabdian kepada Masyarakat (Abdimas)*, 5(1), 55–62. <https://doi.org/10.24843/abdimas.2020.v05.i01.p08>
- Kurniawan, A. & Santosa, D. A. (2019). *Evaluasi Kinerja Instalasi Pengolahan Air Limbah (IPAL) pada Industri Kecil dan Menengah*. Yogyakarta: Penerbit Andi.
- Setyaningsih, W., & Prabowo, H. (2018). *Teknologi Pengolahan Limbah Cair Industri Kecil*. Surabaya: Universitas Airlangga Press.
- SNI 6989.59:2008. (2008). *Air dan Air Limbah – Bagian 59: Cara Uji Kromium Heksavalen (Cr6+) dengan Metode Spektrofotometri*. Jakarta: Badan Standardisasi Nasional.